

Our Production Program



ZZ Bevel Gear Units
up to 7000 Nm nominal torque
or 500 kW power. ZZ Servoline® series
for high-dynamic drives



ZZ Screw Jack Units
with trapezoidal or
ball screw spindle
for loading up to 1000 kN



ZZ Indexing Units
as globoid, cylinder- or
radial cam gear units
with pendular or stepping function



ZZ Spiral Bevel Gears
with - palloid gear tooth system
- Cyclo-palloid gear tooth system
- HPG-S gear tooth system



ZZ Cams
as - Globoid cams
- Axial cams
- Radial cams

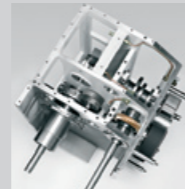

ZZ Special Gear Units
for versatile use in many
different types of application

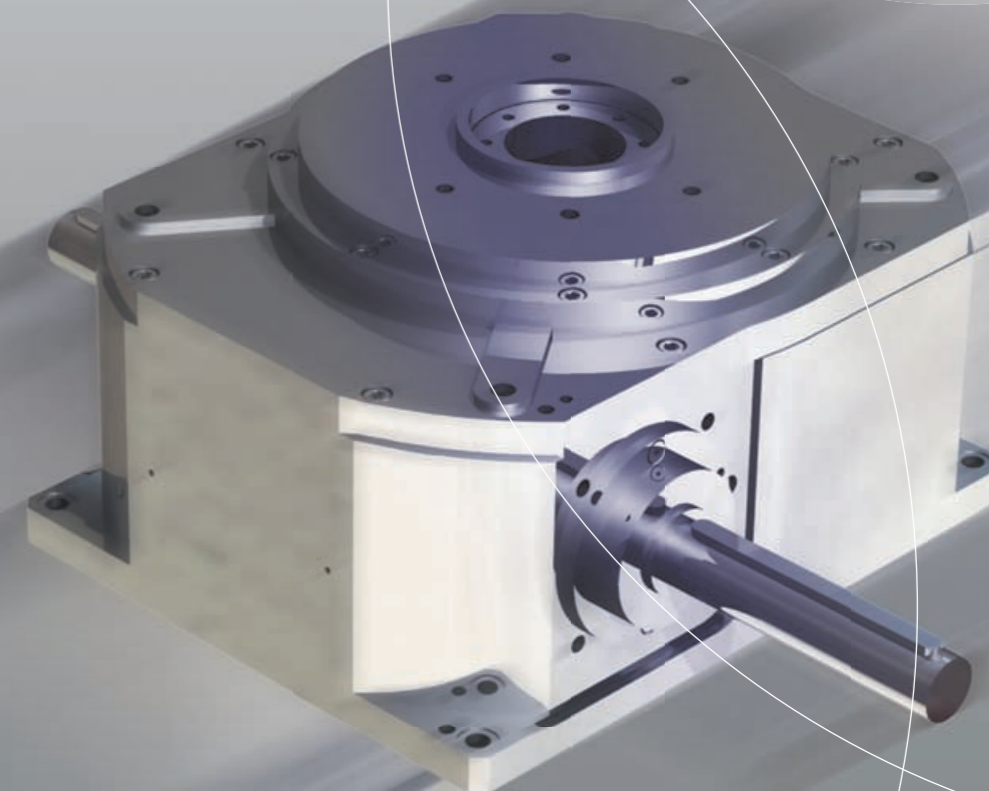

Rotary indexing table type XZ
Ring indexing table type XL

Rotary indexing table type XZ

Rotary indexing tables type XZ are based on a cylindrical cam in which the cam follower intervenes perpendicularly. Thus the output-hollow shaft, on which the cam follower is mounted, can be designed with large diameters.

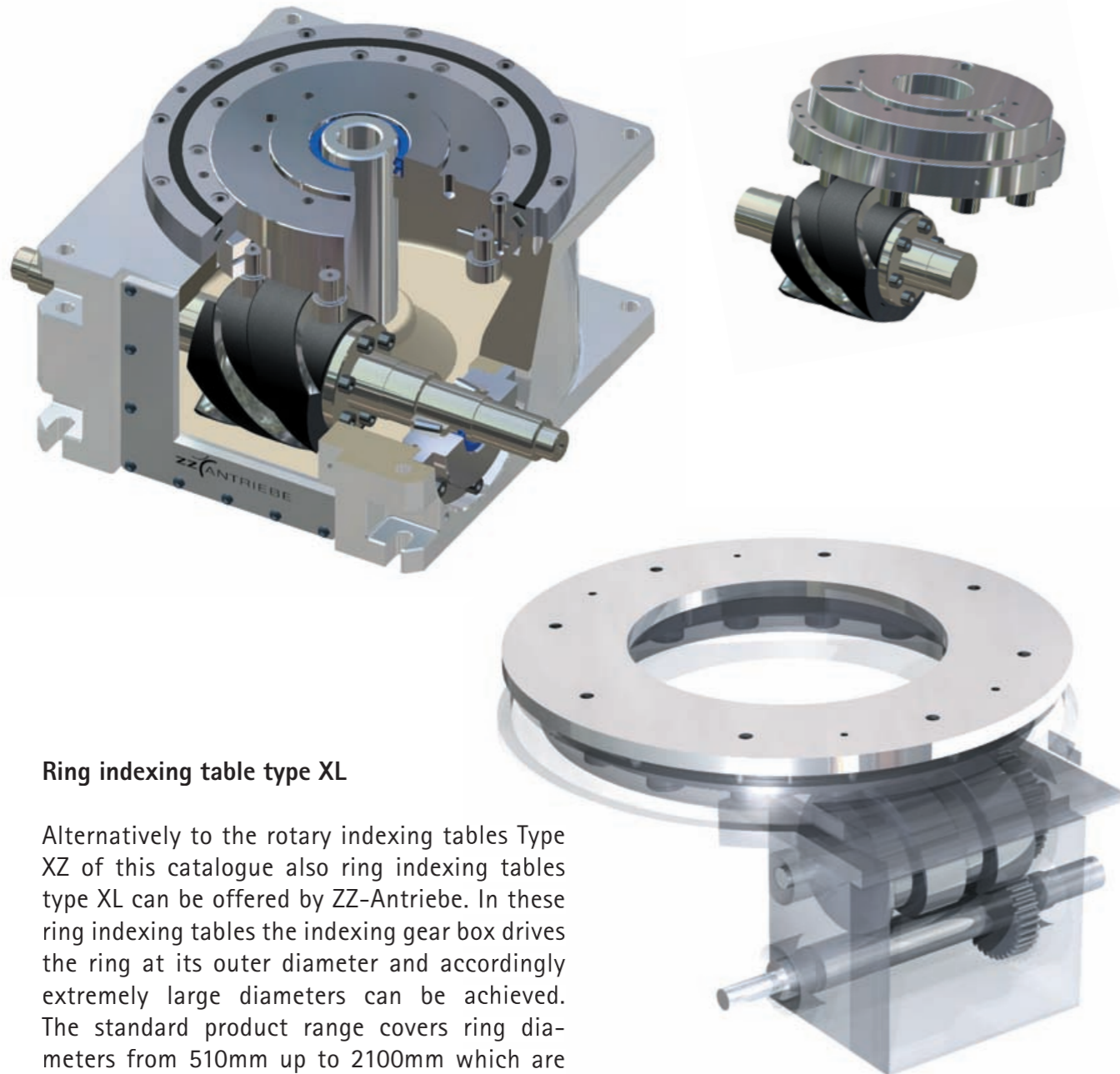

Ring indexing table type XL

Alternatively to the rotary indexing tables Type XZ of this catalogue also ring indexing tables type XL can be offered by ZZ-Antriebe. In these ring indexing tables the indexing gear box drives the ring at its outer diameter and accordingly extremely large diameters can be achieved. The standard product range covers ring diameters from 510mm up to 2100mm which are documented in a separate catalogue.

For further information please visit:
www.zz-antriebe.de

Rotary indexing table
type XZ



Rotary indexing table type XZ

ZZ cam gears provide a fast mechanical and positional transfer of drive for bulk materials and smaller items. The ZZ rotary indexing table type XZ converts a constant movement of the input shaft to an intermittent movement of the output shaft by way of axles set at right angles to each other. The contour of the cam profile, determines the rotation of the table from specific mathematical rules of acceleration in conjunction with the corresponding dwell phase. Between 2 and 32 stations are possible on the output shaft.

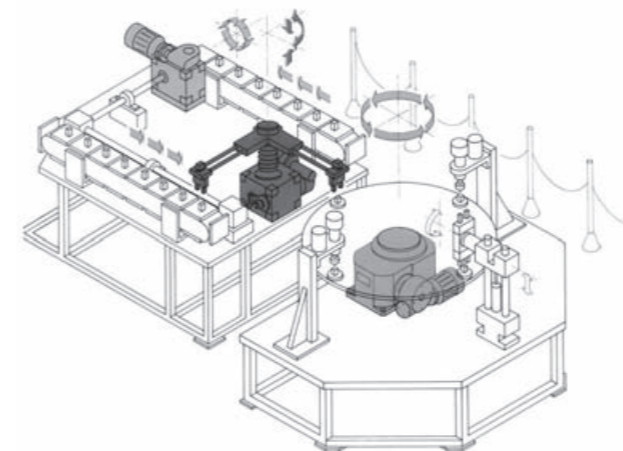

Fields of Application

Mechanical intermittent gears are ideally suited to the requirements of high productivity, in particular to high speeds, accuracy, low noise and minimal running costs. Typical examples of application include:

- Assembly systems
- Packing machines
- Production machines
- Automatic welding machines
- Transport systems
- Processing islands
- Bottling machines
- Printing presses

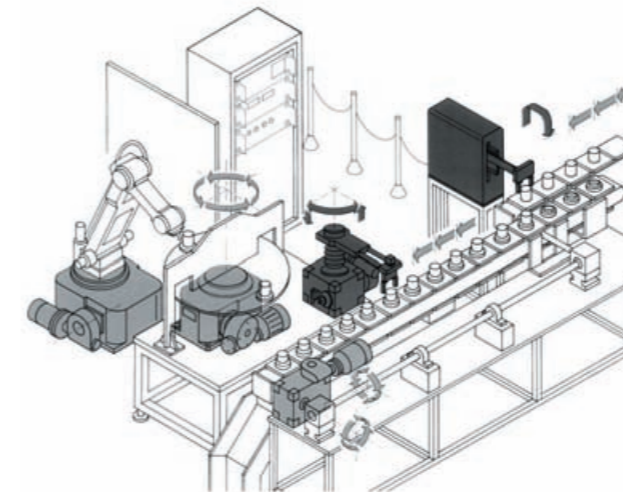

Advantages of ZZ Rotary Indexing Tables

- Precisely controlled clock speed
- Smooth operation, even at high indexing (switching) rates
- Interlocking during the dwell phase
- Accurate repeatability
- Free from any vibration
- Minimum maintenance
- Minimum power consumption

Description:

To achieve a complete working cycle, the input shaft must revolve by 360°. The intermittent movement is given by the shape of the cam path. The input torque is converted to output torque by the cam. During the indexing process, the cam profile-pair moves the rollers through the indexing cam. At least two rollers are always engaged so that at each point of movement, there is no occurrence of play or backlash. The indexing plate is smoothly controlled throughout the entire indexing process. The shape of the cam transfers the acceleration and movement rules specified in the project phase. During the dwell phase, the profile of the cam is orthogonal to the plane of the cam shaft to ensure self-locking.

Direction of Rotation

As standard, the ZZ rotary indexing table is manufactured with right-handed cams. A clockwise rotation of the input shaft produces an intermittent rotation of the output shaft in a counter-clockwise direction. To achieve the opposite rotation, simply reverse the movement of the input shaft. As an option, the drive can be supplied with left-handed cams.

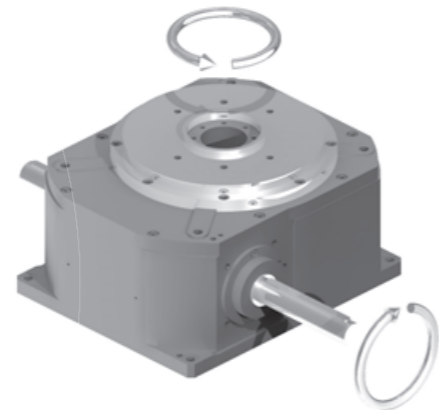

Reference Position

The input shaft of a rotary indexing table incorporates a feather key that can be used as a reference position. When the feather key is uppermost at 90° to the top surface, the drive is in the middle of the latching phase (Pos. 1). With double-indexing, the indexing plate completes two indexing and two latching phases for each revolution of the input shaft (Pos. 2).

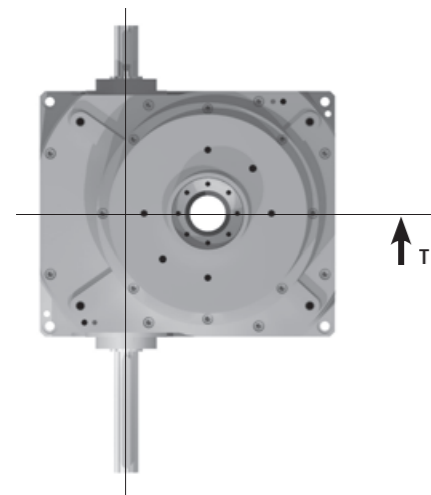
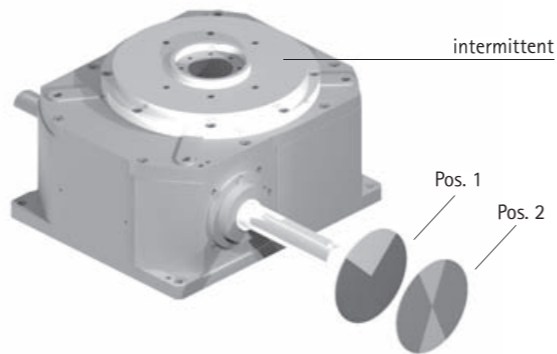
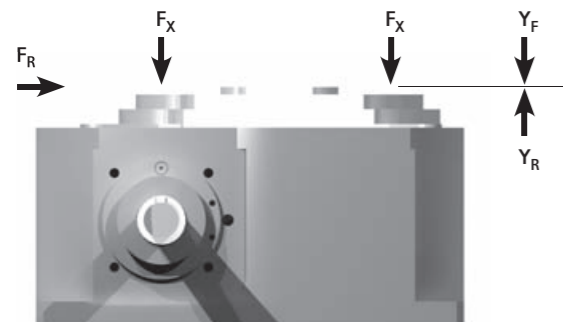
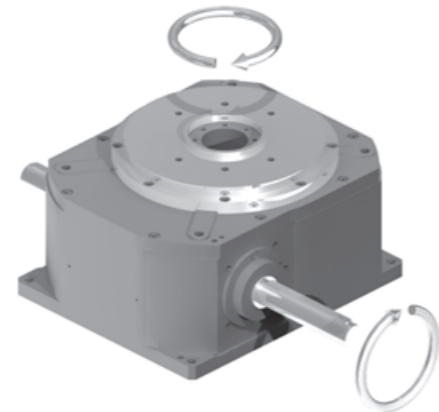

Maximum table load				
Type	Combination		Bending torque Y _F [daNm]	Overturning torque Y _R [daNm]
	Axial load F _X (daN)	Radial load F _R (daN)		
XZ038	650	650	18	9
XZ050	1100	1100	32	20
XZ080	1800	1800	68	38
XZ100	3000	3000	118	70
XZ140	4300	4300	248	140
XZ165	6000	6000	350	200
XZ210	8000	8000	400	300
XZ270	10000	10000	800	700
XZ380	15000	15000	1100	1000

Permissible Indexing Angle depending on the Number of Stations and the Gear Size

Type	Stat.	Indexing angle										Type	Stat.	Indexing angle									
		90°	120°	150°	180°	210°	240°	270°	300°	330°	90°			120°	150°	180°	210°	240°	270°	300°	330°		
XZ038	2											XZ038	8										
XZ050												XZ050											
XZ080												XZ080											
XZ100												XZ100											
XZ140												XZ140											
XZ165												XZ165											
XZ210												XZ210											
XZ270												XZ270											
XZ380											XZ380												
XZ038	3										XZ038	9											
XZ050											XZ050												
XZ080											XZ080												
XZ100											XZ100												
XZ140											XZ140												
XZ165											XZ165												
XZ210											XZ210												
XZ270											XZ270												
XZ380										XZ380													
XZ038	4										XZ038	10											
XZ050											XZ050												
XZ080											XZ080												
XZ100											XZ100												
XZ140											XZ140												
XZ165											XZ165												
XZ210											XZ210												
XZ270											XZ270												
XZ380										XZ380													
XZ038	5										XZ038	12											
XZ050											XZ050												
XZ080											XZ080												
XZ100											XZ100												
XZ140											XZ140												
XZ165											XZ165												
XZ210											XZ210												
XZ270											XZ270												
XZ380										XZ380													
XZ038	6										XZ038	14											
XZ050											XZ050												
XZ080											XZ080												
XZ100											XZ100												
XZ140											XZ140												
XZ165											XZ165												
XZ210											XZ210												
XZ270											XZ270												
XZ380										XZ380													
XZ038	7										XZ038	15											
XZ050											XZ050												
XZ080											XZ080												
XZ100											XZ100												
XZ140											XZ140												
XZ165											XZ165												
XZ210											XZ210												
XZ270											XZ270												
XZ380										XZ380													

Recommended indexing angle with brake-motors
 Recommended indexing angle
 Feasible indexing angle

Repeatability

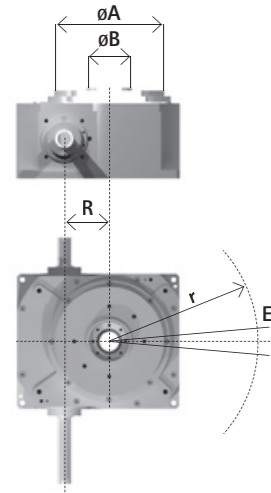

TOLERANCE OF ROTARY INDEXING TABLES							
Type	Repeatability			Table flatness		Table excentricity	
	R (mm)	Standard +/- (mm)	Special +/- (mm)	A (mm)	Total (mm)	B (mm)	Total (mm)
XZ038	37.5	0.015	0.010	120	0.010	30	0.010
XZ050	50.0	0.015	0.010	130	0.010	65	0.010
XZ080	80.0	0.015	0.010	195	0.010	80	0.010
XZ100	100.0	0.015	0.010	250	0.015	130	0.015
XZ140	140.0	0.015	0.010	350	0.015	200	0.015
XZ165	165.0	0.015	0.010	435	0.015	230	0.020
XZ210	210.0	0.015	0.010	535	0.020	230	0.030
XZ270	270.0	0.020	0.010	700	0.030	320	0.030
XZ380	380.0	0.020	0.010	1000	0.030	400	0.030

Installation Position

As standard, the housing of the rotary indexing table is finished without shafts on the top and lower sides as well as the end face. The recommended position for installation, together with possible positions for fixing the motor, are shown in the following diagrams. By request, other installation positions are possible.

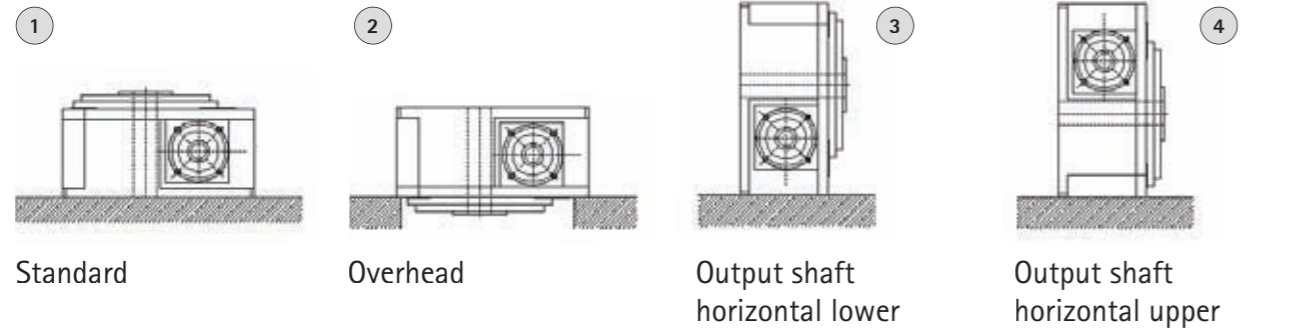

Standard motor installation

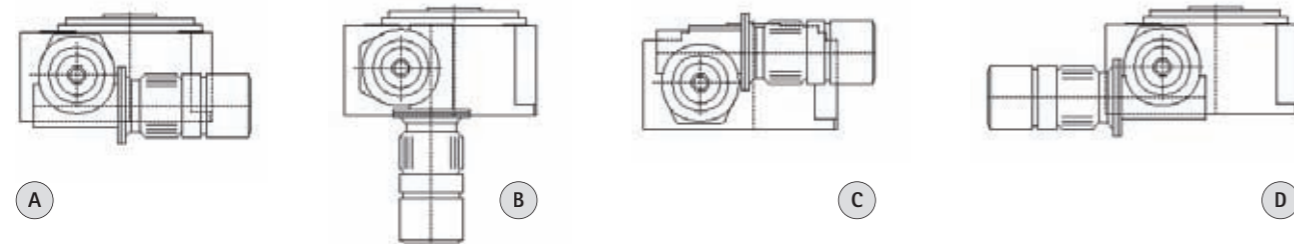

Motor installation on the opposite side

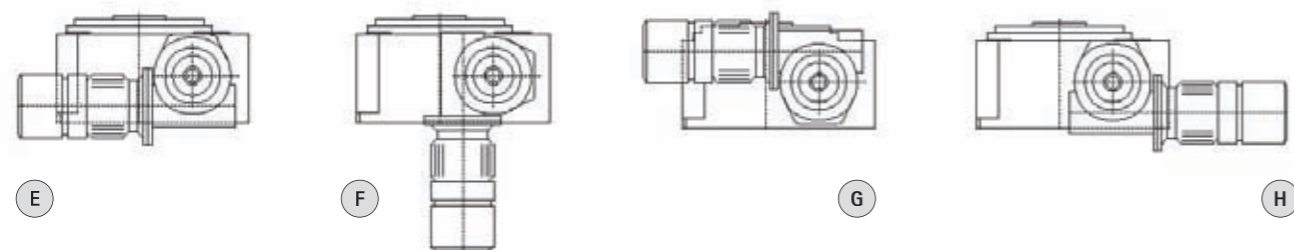

Stations (S)	Indexing angle (... °)	Gear type	Statical torque (M _p) [daNm]	Output torque M _A (daNm)						Std. coefficients		
				Cycles / min.						Speed C _v	Accel. C _a	Drive K
				25	50	75	100	150	200			
2	300	XZ038	13	10	10	10	10	9	1.13	10.72	0.34	
		XZ050	22	17	17	16	16	15	1.31	7.43	0.44	
		XZ080	45	30	30	29	29	28	1.40	6.61	0.47	
		XZ100	120	84	84	84	83	82	1.40	6.61	0.47	
		XZ140	330	180	180	179	178	174	1.76	5.53	0.58	
		XZ165	574	237	235	231	225	218	1.76	5.53	0.26	
		XZ210	600	300	296	289	279	254	210	1.40	6.61	0.47
		XZ270	2105	1255	1240	1210	1176	1066	914	1.40	6.61	0.47
		XZ380	2300	1773	1700	1579	1409			1.40	6.61	0.47
		XZ038	13	11	11	11	10	10	10	1.13	10.72	0.32
		XZ050	22	18	18	18	17	17	17	1.40	6.61	0.45
		XZ080	45	32	32	32	31	30	30	1.40	6.61	0.45
	XZ100	120	86	86	86	86	84	83	1.40	6.61	0.45	
	XZ140	330	187	187	186	185	182	178	1.76	5.53	0.56	
	XZ165	574	247	245	241	236	229	201	1.76	5.53	0.23	
	XZ210	600	320	317	310	302	278	245	1.40	6.61	0.45	
	XZ270	2105	1300	1290	1260	1185	1128	991	1.40	6.61	0.45	
	XZ380	2300	1844	1778	1668	1514			1.40	6.61	0.45	
	XZ038	13	11	11	11	11	10	10	1.13	10.72	0.32	
	XZ050	22	19	18	18	18	17	17	1.40	6.61	0.43	
	XZ080	45	35	35	35	34	33	33	1.40	6.61	0.43	
	XZ100	120	90	90	90	89	88	87	1.40	6.61	0.43	
	XZ140	330	195	195	193	192	189	186	1.76	5.53	0.53	
	XZ165	574	257	255	251	247	241	214	1.76	5.53	0.22	
XZ210	600	335	331	326	318	298	268	1.40	6.61	0.43		
XZ270	2105	1350	1340	1315	1285	1193	1069	1.40	6.61	0.43		
XZ380	2300	1912	1852	1752	1611	1210		1.40	6.61	0.43		
3	240	XZ038	12	8	8	8	8	7	1.40	6.61	0.39	
		XZ050	20	16	16	16	16	15	15	1.76	5.53	0.48
		XZ080	42	25	25	25	25	24	24	1.76	5.53	0.48
		XZ100	115	71	71	70	70	69	69	1.76	5.53	0.48
		XZ140										
		XZ165										
		XZ210										
		XZ270										
		XZ380										
		XZ038	12	8	8	8	8	8	7	1.40	6.61	0.35
		XZ050	20	16	16	16	16	15	15	2.00	6.28	0.58
		XZ080	42	28	28	28	28	27	27	1.76	5.53	0.43
	XZ100	115	89	89	88	88	87	86	1.40	6.61	0.35	
	XZ140	300	226	225	224	223	221	217	1.76	5.53	0.43	
	XZ165	567	263	261	259	255	250	229	2.00	6.28	0.52	
	XZ210	560	300	297	292	284	264	235	2.00	6.28	0.58	
	XZ270	2140	1325	1315	1300	1270	1193	1089	1.76	5.53	0.43	
	XZ380	2300	1885	1835	1752	1635	1300		1.76	5.53	0.43	
	XZ038	12	9	9	9	9	9	8	1.40	6.61	0.31	
	XZ050	20	17	17	17	16	16	16	2.00	6.28	0.52	
	XZ080	42	31	31	30	30	29	29	1.76	5.53	0.39	
	XZ100	115	90	90	88	88	87	86	1.76	5.53	0.39	
	XZ140	300	242	241	240	239	238	235	1.76	5.53	0.39	
	XZ210	560	350	348	344	339	325	305	1.76	5.53	0.39	
XZ270	2140	1435	1425	1410	1390	1329	1244	1.76	5.53	0.39		
XZ380	2300	2040	2000	1930	1838	1567		1.76	5.53	0.39		
XZ038	12	10	9	9	9	8	8	1.76	5.53	0.37		
XZ050	20	18	18	18	18	17	17	2.00	6.28	0.49		
XZ080	42	32	32	31	31	30	30	1.76	5.53	0.37		
XZ100	115	86	86	85	85	84	83	2.00	6.28	0.49		
XZ140	300	250	249	248	247	246	243	1.76	5.53	0.37		
XZ210	560	364	362	358	354	341	322	1.76	5.53	0.37		
XZ270	2140	1491	1483	1469	1449	1395	1318	1.76	5.53	0.37		
XZ380	2300	2110	2075	2015	1929	1684	1340	1.76	5.53	0.37		
XZ038	12	10	10	10	9	9	8	1.76	5.53	0.35		
XZ050	20	19	19	19	19	18	18	2.00	6.28	0.47		
XZ080	42	33	33	32	32	31	31	1.76	5.53	0.35		
XZ100	115	89	89	89	88	87	87	2.00	6.28	0.47		
XZ140	300	255	254	253	252	250	248	1.76	5.53	0.35		
XZ210	560	376	375	372	367	356	339	1.76	5.53	0.35		
XZ270	2140	1540	1532	1519	1502	1453	1382	1.76	5.53	0.35		
XZ380	2300	2182	2148	2092	2014	1791	1478	1.76	5.53	0.35		
4	180	XZ038	13	8	8	8	8	7	1.40	6.61	0.39	
		XZ050	22	16	16	16	16	15	15	1.76	5.53	0.49
		XZ080	45	25	25	25	25	24	24	1.76	5.53	0.49
		XZ100	120	93	93	93	92	90	89	1.40	6.61	0.39
		XZ140	330	207	206	205	203	199	192	1.76	5.53	0.49
		XZ165	441	185	182	177	171	163	129	1.40	6.61	0.17
		XZ210	600	325	321	313	301	285	260	1.76	5.53	0.49
		XZ270										
		XZ380										
		XZ038	13	9	9	9	9	8	7	1.40	6.61	0.29
		XZ050	22	20	20	20	20	19	18	1.40	6.61	0.29
		XZ080	45	29	29	29	28	28	27	2.00	6.28	0.48
	XZ100	120	96	96	95	95	93	92	1.76	5.53	0.36	
	XZ140	330	220	219	218	216	214	211	2.00	6.28	0.48	
	XZ210	600	340	337	331	324	306	279	2.00	6.28	0.48	
	XZ270											
	XZ380											
	XZ038	13	10	10	9	9	9	8	1.40	6.61	0.29	
	XZ050	22	20	20	20	20	19	19	1.76	5.53	0.32	
	XZ080	45	32	32	31	31	30	29	2.00	6.28	0.43	
	XZ100	120	96	95	95	94	93	92	2.00	6.28	0.43	
	XZ140	330	230	229	228	227	225	222	2.00	6.28	0.43	
	XZ165	567	325	323	321	319	315	299	1.76	5.53	0.18	
	XZ210	600	375	373	369	363	349	327	2.00	6.28	0.43	
XZ270	2200	1625	1615	1600	1585	1524	1444	1.76	5.53	0.32		
XZ380	2900	2300	2269	2205	2115	1861	1500	1.76	5.53	0.32		

Stations (S)	Indexing angle (... °)	Gear type	Statical torque (M _p) [daNm]	Output torque M _A (daNm)						Std. coefficients		
				Cycles / min.						Speed	Accel.	Drive
				25	50	75	100	150	200			
12	150	XZ038	14	12	12	12	12	11	1.76	5.53	0.19	
		XZ050	25	23	23	22	22	21	1.27	8.01	0.14	
		XZ080	50	41	41	41	40	39	2.00	6.28	0.26	
		XZ100	135	117	117	116	116	114	113	2.00	6.28	0.26
		XZ140	375	336	335	334	333	330	327	1.76	5.53	0.19
		XZ210										
	180	XZ038	14	13	13	13	12	12	1.76	5.53	0.16	
		XZ050	25	24	24	23	23	22	22	1.76	5.53	0.16
		XZ080	50	43	43	43	42	41	41	2.00	6.28	0.21
		XZ100	135	123	122	122	121	120	119	2.00	6.28	0.21
		XZ140	375	352	351	350	348	346	344	1.76	5.53	0.16
		XZ210										
	240	XZ038	14	14	14	14	13	13	12	1.76	5.53	0.12
		XZ050	25	25	24	24	23	23	23	2.00	6.28	0.16
		XZ080	50	46	46	46	45	44	43	2.00	6.28	0.16
		XZ100	135	129	128	128	127	126	125	2.00	6.28	0.16
		XZ140	375	364	363	361	360	358	356	2.00	6.28	0.16
		XZ210										
	270	XZ038	14	14	14	14	14	13	13	1.76	5.53	0.11
		XZ050	25	25	25	25	24	24	23	2.00	6.28	0.14
		XZ080	50	47	47	46	46	45	45	2.00	6.28	0.14
		XZ100	135	130	130	129	129	128	127	2.00	6.28	0.14
		XZ140	375	372	371	370	369	367	365	2.00	6.28	0.14
		XZ210	660	644	643	642	640	635	627	2.00	6.28	0.14
16	90	XZ038	14	11	11	11	11	10	1.76	5.53	0.09	
		XZ050	26	22	22	22	21	21	20	1.76	5.53	0.09
		XZ080	50	40	40	40	39	38	37	1.76	5.53	0.09
		XZ100	135	124	123	122	122	120	119	1.27	8.01	0.18
		XZ140	200	159	158	157	155	151	144	1.76	5.53	0.09
		XZ210	441	299	296	292	286	277	242	2.00	6.28	0.19
	120	XZ038	14	12	12	12	11	11	10	1.76	5.53	0.37
		XZ050	26	23	23	23	22	22	21	2.00	6.28	0.48
		XZ080	50	42	42	42	41	40	39	2.00	6.28	0.24
		XZ100	135	128	127	126	126	124	123	1.40	6.61	0.14
		XZ140	200	175	175	174	174	171	167	1.76	5.53	0.18
		XZ210										
	150	XZ038	14	13	13	13	12	12	11	2.00	6.28	0.39
		XZ050	26	24	23	23	22	21	21	2.00	6.28	0.39
		XZ080	50	45	45	44	44	43	42	2.00	6.28	0.19
		XZ100	135	131	130	130	129	128	127	1.40	6.61	0.12
		XZ140	200	185	185	184	184	182	180	1.76	5.53	0.12
		XZ210										
	180	XZ038	14	13	13	13	13	12	12	2.00	6.28	0.32
		XZ050	26	24	24	24	24	23	22	2.00	6.28	0.32
		XZ080	50	46	46	46	45	44	43	2.00	6.28	0.16
		XZ100	135	131	130	130	129	127	126	1.76	5.53	0.12
		XZ140	200	191	191	191	190	189	187	1.76	5.53	0.12
		XZ210										
240	XZ038	14	14	14	14	13	13	12	2.00	6.28	0.24	
	XZ050	26	25	25	25	24	24	23	2.00	6.28	0.24	
	XZ080	50	48	48	47	47	46	45	2.00	6.28	0.12	
	XZ100	135	132	131	131	130	130	129	2.00	6.28	0.12	
	XZ140	200	195	195	195	195	194	193	2.00	6.28	0.12	
	XZ210											
270	XZ038	14	14	14	14	13	13	12	2.00	6.28	0.22	
	XZ050	26	26	26	25	25	24	24	2.00	6.28	0.22	
	XZ080	50	48	48	48	48	47	46	2.00	6.28	0.11	
	XZ100	135	134	133	133	132	131	130	2.00	6.28	0.11	
	XZ140	200	197	197	197	197	196	195	2.00	6.28	0.11	
	XZ210	700	679	678	677	676	672	667	2.00	6.28	0.11	
24	90	XZ038	14	12	11	11	11	10	1.76	5.53	0.32	
		XZ050	26	23	23	23	22	22	22	1.76	5.53	0.32
		XZ080	50	45	45	45	44	43	42	1.76	5.53	0.32
		XZ100	140	126	125	124	123	122	121	1.76	5.53	0.32
		XZ140	400	350	349	347	346	342	337	1.76	5.53	0.32
		XZ210										
	120	XZ038	14	13	13	12	12	12	11	1.76	5.53	0.24
		XZ050	26	24	24	23	23	22	22	2.00	6.28	0.32
		XZ080	50	46	46	46	45	44	43	2.00	6.28	0.32
		XZ100	140	129	128	128	127	125	124	2.00	6.28	0.32
		XZ140	400	360	359	368	356	353	349	2.00	6.28	0.32
		XZ210										

Stations (S)	Indexing angle (... °)	Gear type	Statical torque (M _p) [daNm]	Output torque M _A (daNm)						Std. coefficients		
				Cycles / min.						Speed	Accel.	Drive
				25	50	75	100	150	200			
24	150	XZ038	14	13	13	13	13	13	12	2.00	6.28	0.26
		XZ050	26	24	24	24	24	23	23	2.00	6.28	0.26
		XZ080	50	48	47	47	47	46	45	2.00	6.28	0.26
		XZ100	140	132	131	130	130	129	128	2.00	6.28	0.26
		XZ140	400	375	374	373	372	369	366	2.00	6.28	0.26
		XZ210										
	180	XZ038	14	14	14	14	13	13	12	2.00	6.28	0.22
		XZ050	26	25	24	24	24	23	23	2.00	6.28	0.22
		XZ080	50	48	48	48	47	46	46	2.00	6.28	0.22
		XZ100	140	134	133	133	132	130	129	2.00	6.28	0.22
		XZ140	400	384	383	382	380	378	376	2.00	6.28	0.22
		XZ210										
	240	XZ038	15	15	15	14	14	14	13	2.00	6.28	0.16
		XZ050	26	25	25	25	24	24	23	2.00	6.28	0.16
		XZ080	50	49	49	48	48	47	47	2.00	6.28	0.16
		XZ100	140	135	135	134	134	133	132	2.00	6.28	0.16
		XZ140	400	392	391	390	389	387	385	2.00	6.28	0.16
		XZ210										
	270	XZ038	15	15	15	15	14	14	13	2.00	6.28	0.14
		XZ050	26	26	26	25	25	24	24	2.00	6.28	0.14
		XZ080	50	49	49	49	49	48	47	2.00	6.28	0.14
		XZ100	140	136	136	135	135	134	133	2.00	6.28	0.14
		XZ140	400	394	393	392	391	389	387	2.00	6.28	0.14
		XZ210	720	707	706	705	704	699	696	2.00	6.28	0.14
32	90	XZ038	14	11	11	11	11	10	1.76	5.53	0.24	
		XZ050	26	22	22	22	21	21	20	1.76	5.53	0.24
		XZ080	50	47	47	47	46	45	44	1.76	5.53	0.24
		XZ100	140	131	130	129	129	127	126	1.76	5.53	0.24
		XZ140	210	191	190	189	187	185	182	1.76	5.53	0.24
		XZ210										
	120	XZ038	14	12	12	12	11	11	10	1.76	5.53	0.24
		XZ050	26	23	23	23	22	22	21	2.00	6.28	0.24
		XZ080	50	42	42	42	41	40	39	2.00	6.28	0.24
		XZ100	140	132	131	131	130	129	128	2.00	6.28	0.24
		XZ140	210	193	192	190	189	186	183	2.00	6.28	0.24
		XZ210										
	150	XZ038	14	13	13	13	12	12	11	2.00	6.28	0.20
		XZ050	26	24	23	23	22	21	21	2.00	6.28	0.20
		XZ080	50	49	48	48	47	46	45	2.00	6.28	0.20
		XZ100	140	134	133	133	133	132	131	2.00	6.28	0.20
		XZ140	210	199	198	197	195	192	190	2.00	6.28	0.20
		XZ210										
	180	XZ038	14	13	13	13	13	12	12	2.00	6.28	0.16
		XZ050	26	24	24	24	24	23	22	2.00	6.28	0.16
		XZ080	50	49	49	49	48	47	47	2.00	6.28	0.16
		XZ100	140	135	135	134	134	133	132	2.00	6.28	0.16
		XZ140	210	201	200	199	198	195	193	2.00	6.28	0.16
		XZ210										
240	XZ038	14	14	14	14	13	13	12	2.00	6.28	0.12	
	XZ050	26	25	25	25	24	24	23	2.00	6.28	0.12	
	XZ080	50	48	48	48	48	47	46	2.00	6.28	0.12	
	XZ100	140	136	136	135	135	134	133	2.00	6.28	0.12	
	XZ140	210	204	203	202	200	197	195	2.00	6.28	0.12	
	XZ210		</									

XZ 038

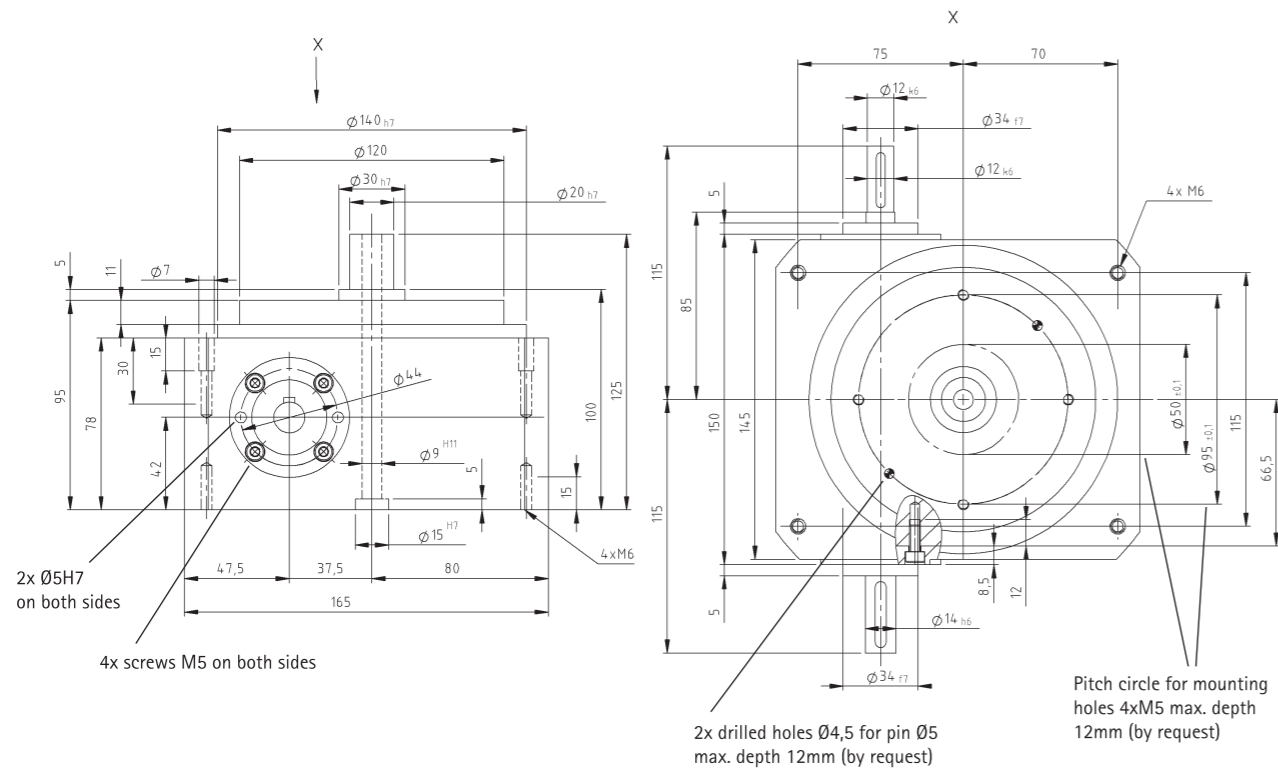

XZ 080

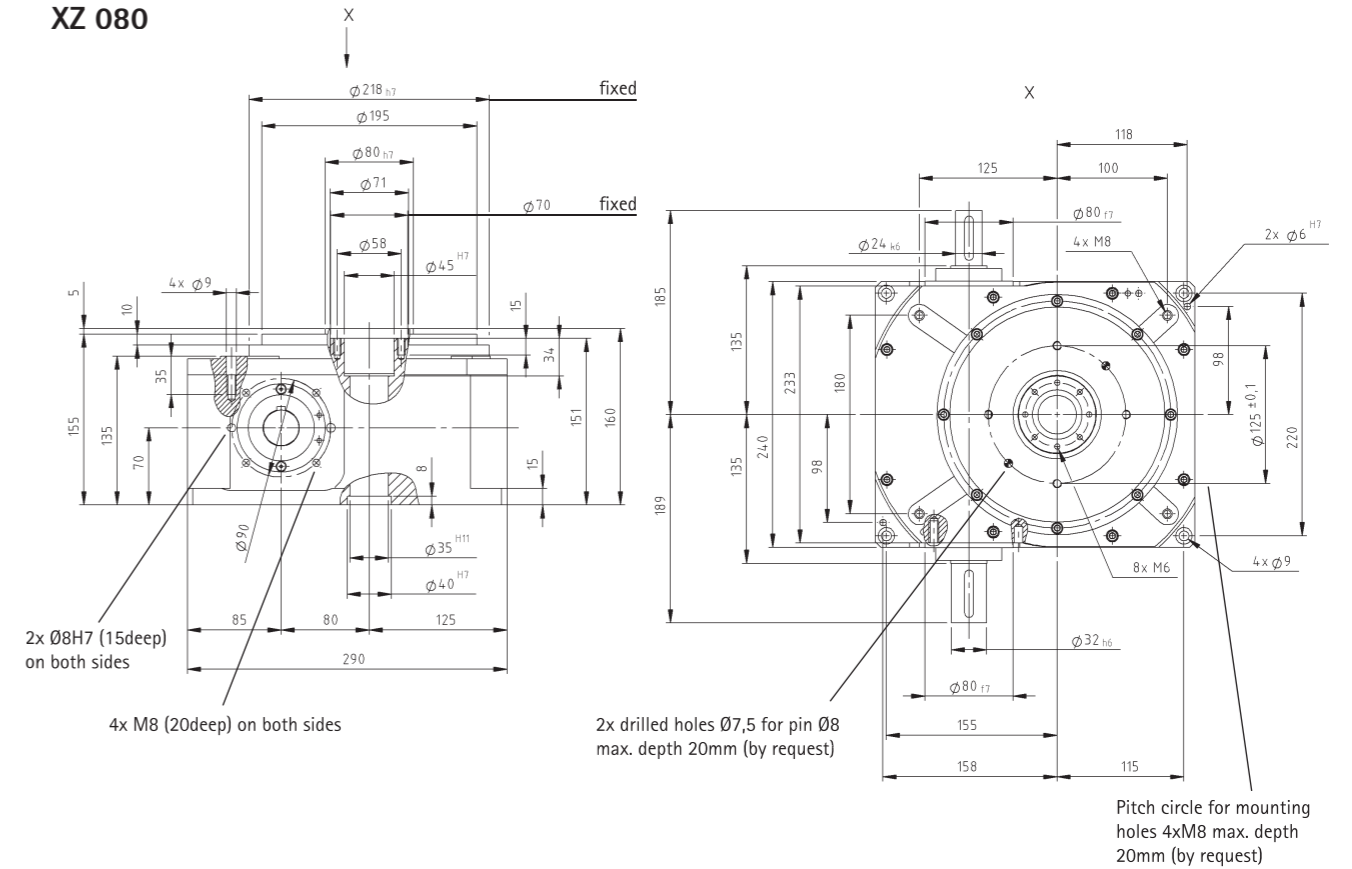

XZ 050

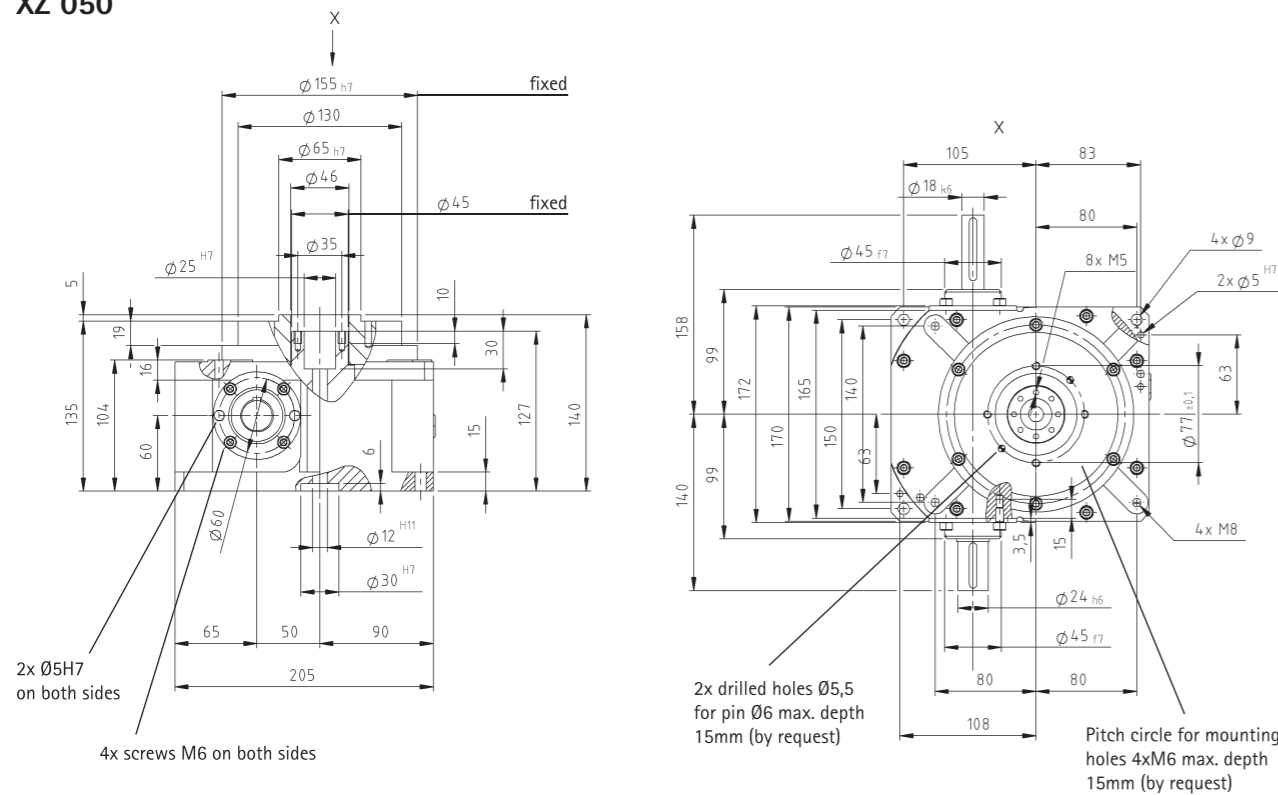

XZ 100

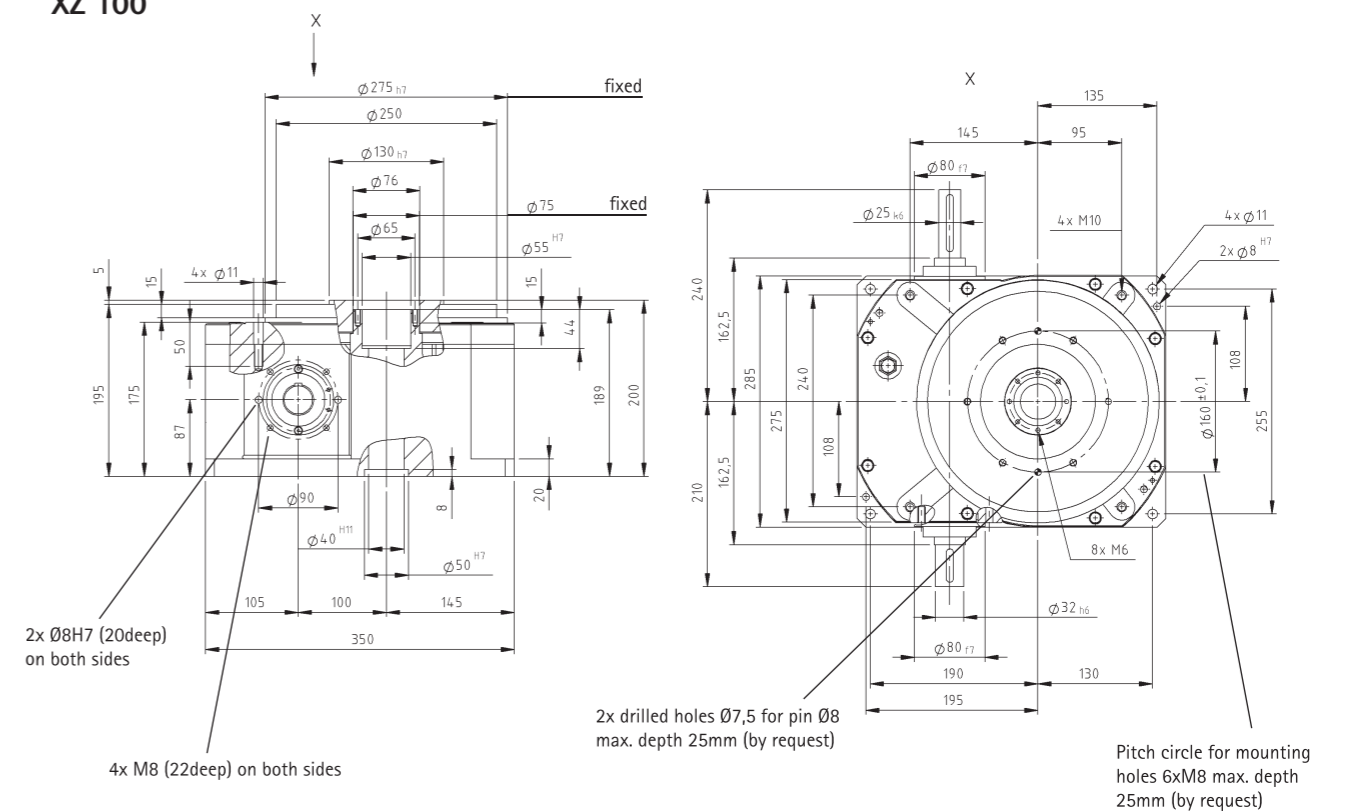

XZ 140

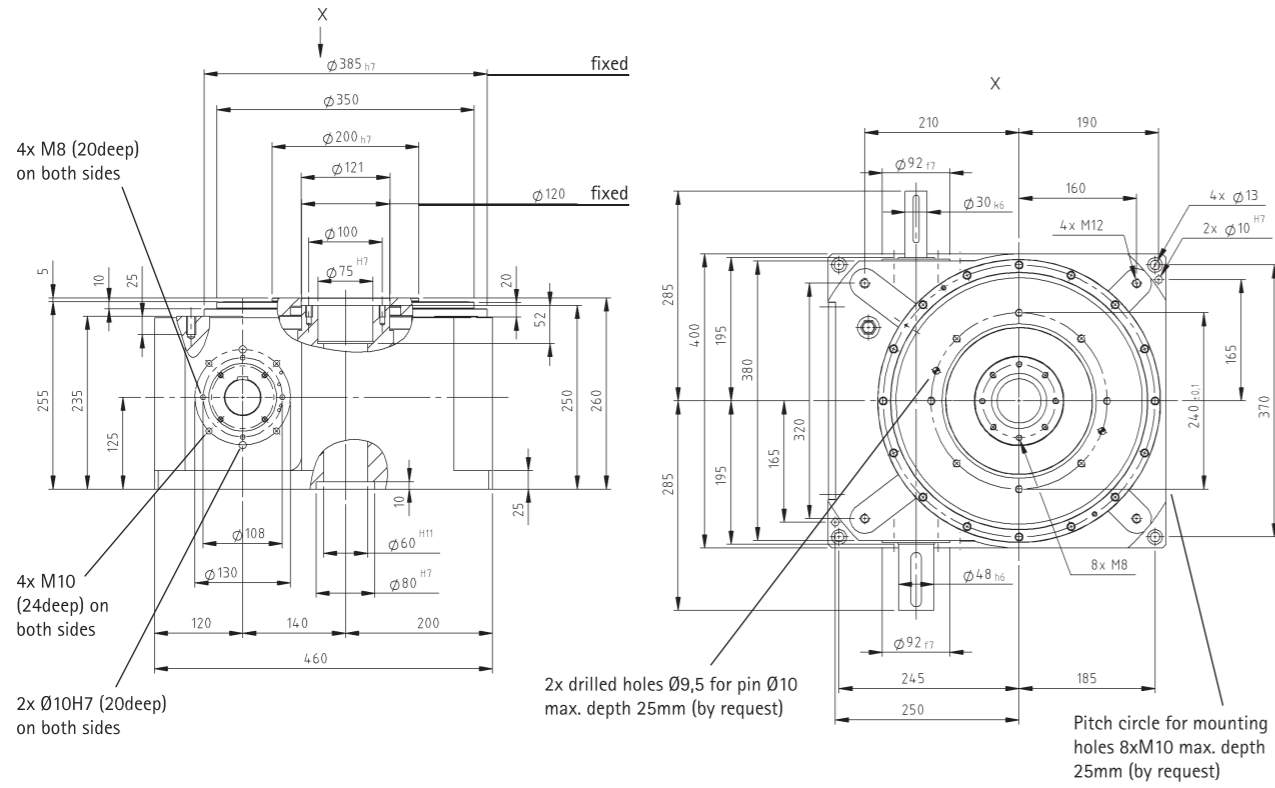

XZ 210

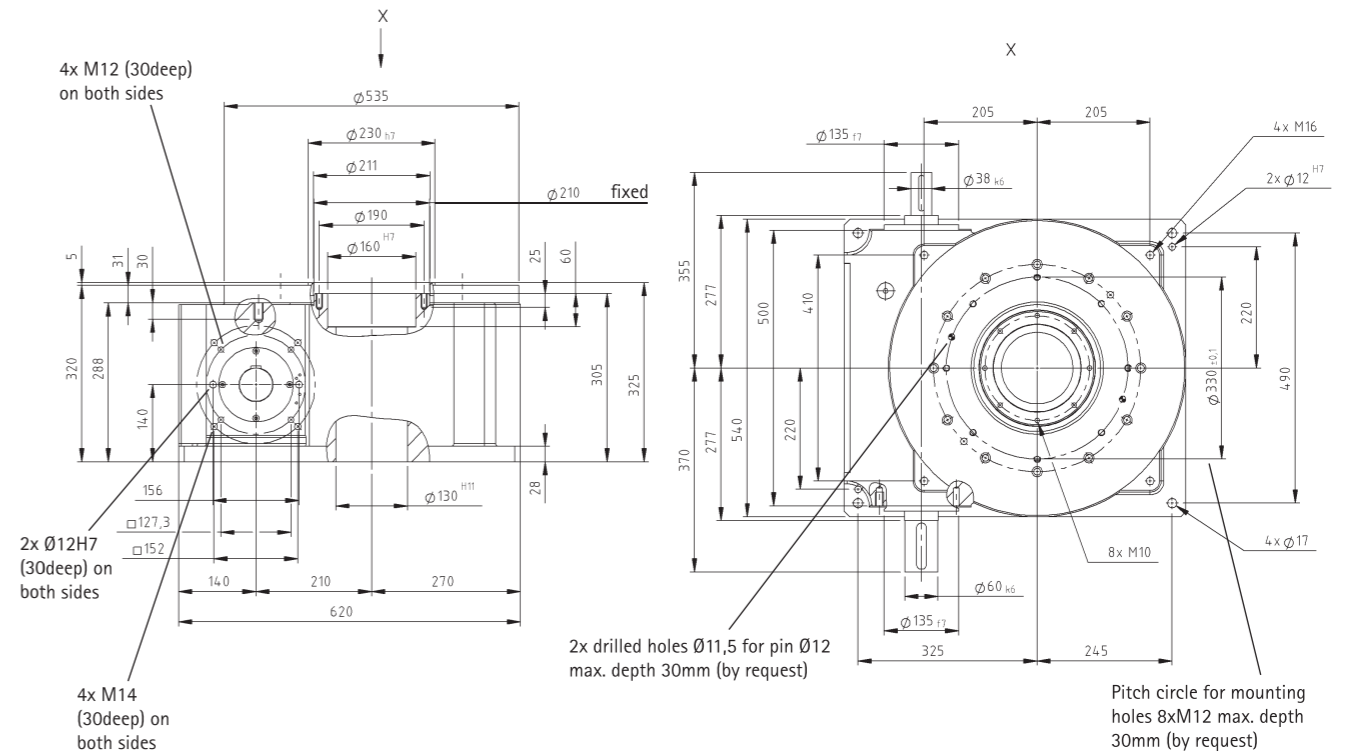

XZ 165

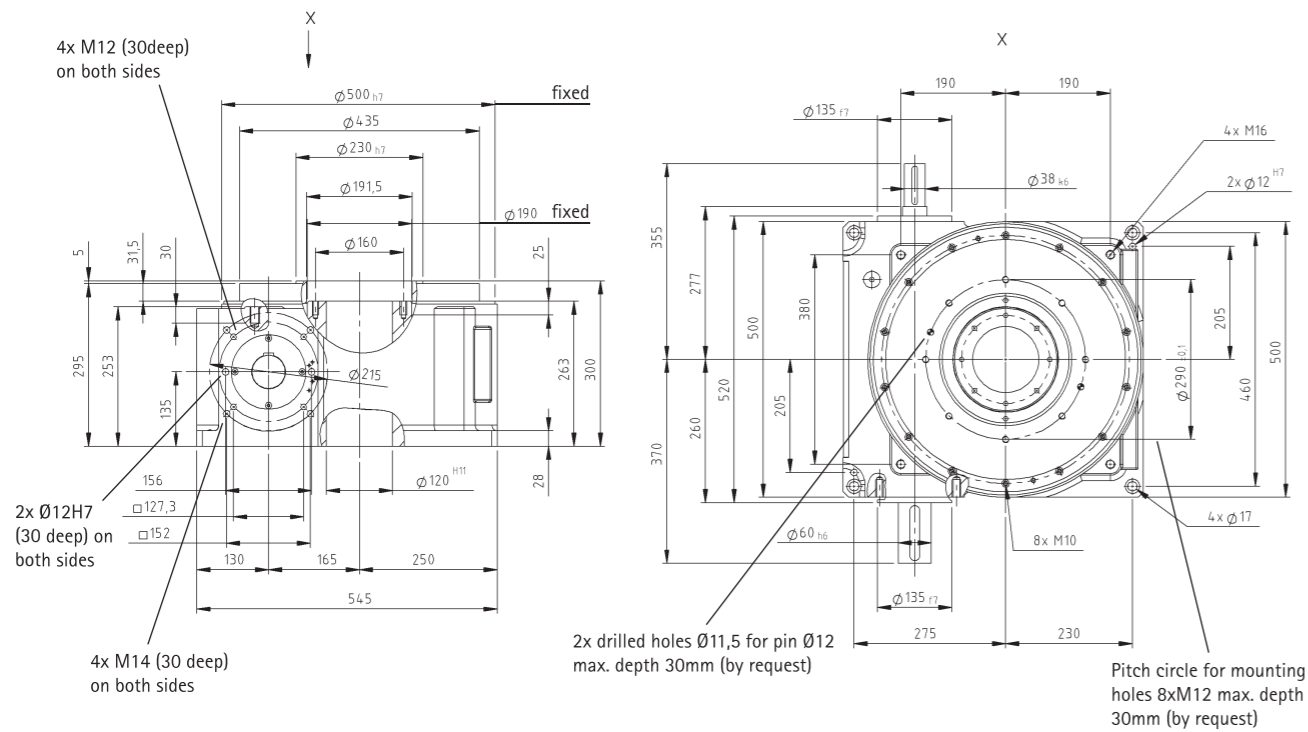

XZ 270

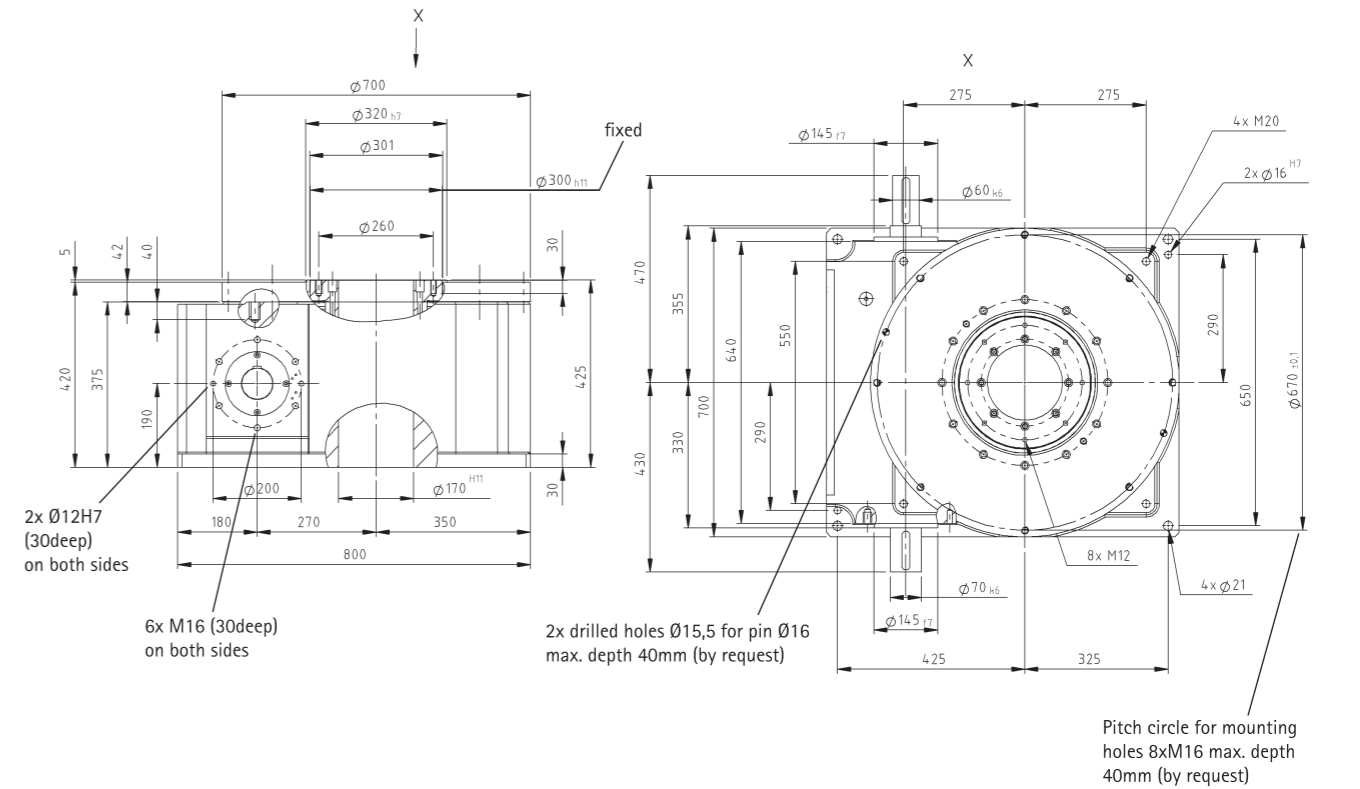

XZ 380

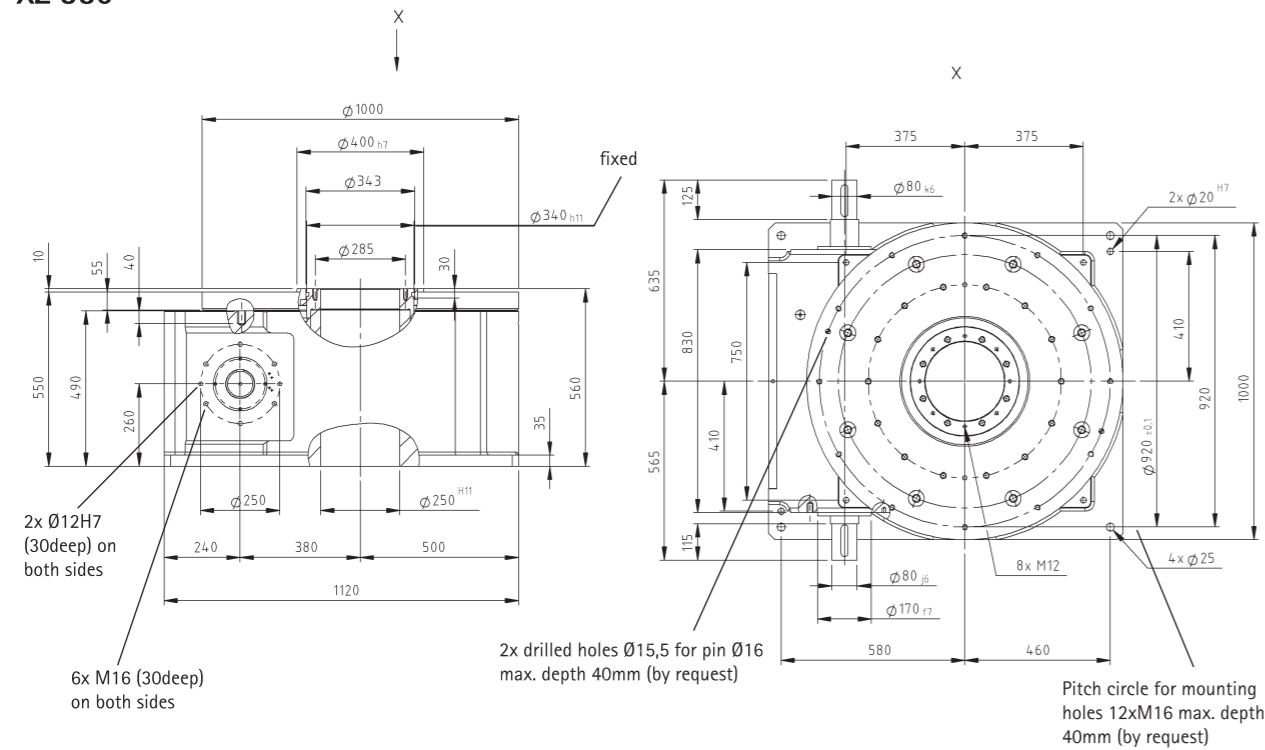

End Switch Dimensions

The rotary indexing table can be fitted with an end switch, activated by a cam mounted on the end of the input shaft. When the dwell angle of the cam is smaller than the dwell time required for the table, the time can be extended by an end switch that controls the (braking) motor.

End Switch, mechanical

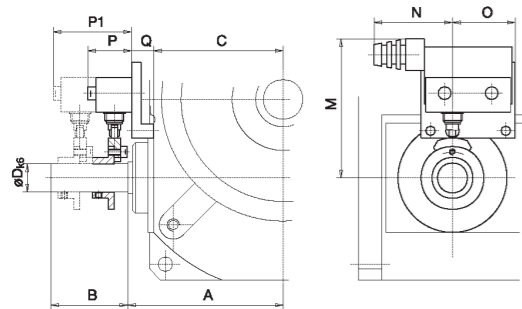

End Switch, inductive

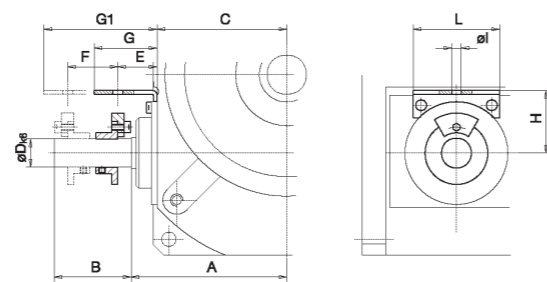

Type	A	B	C	D	E	F	G	G1	H	I	L	M	N	O	P	P1	Q
XZ038	85,0	30,0	75,0	12	15	32	30	60	55	8,5	44	110	50	40	28	55	5
XZ050	99,0	59,0	86,0	18	25	32	40	72	55	8,5	55	110	50	40	28	64	14
XZ080	125,0	50,0	116,5	24	30	35	50	85	55	8,5	50	110	50	40	28	70	20
XZ100	162,5	77,5	137,5	25	30	35	50	85	55	8,5	50	110	50	40	28	70	20
XZ140	195,0	90,0	190,0	30	30	35	50	85	62	8,5	50	115	50	40	28	70	20
XZ165	277,0	78,0	250,0	38	30	35	50	85	70	8,5	50	130	50	40	28	70	20
XZ210	277,0	78,0	250,0	38	30	35	50	85	70	8,5	50	130	50	40	28	70	20
XZ270	355,0	115,0	320,0	60	45	35	65	100	75	8,5	55	130	50	40	28	84	34
XZ380	510,0	125,0	415,0	90	45	35	65	100	88	8,5	55	143	50	40	28	84	34

Globoid Cam Gears

View of the Component Set

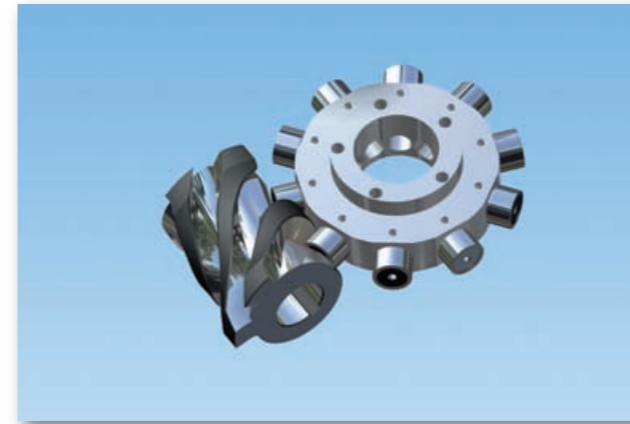

Standard Globoid Cam Gear, Type X

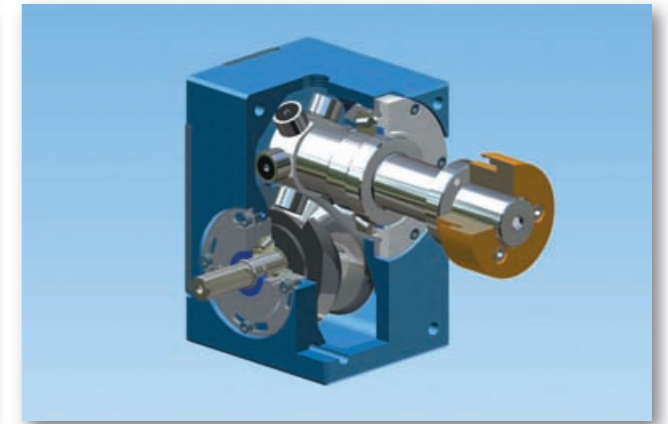

Globoid Cam Gear, Table Version, Type TX

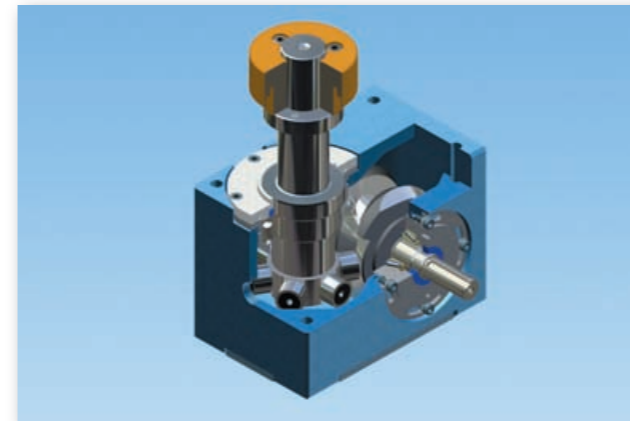

Globoid Cam Gear, Rotary Indexing Table, Type RTX

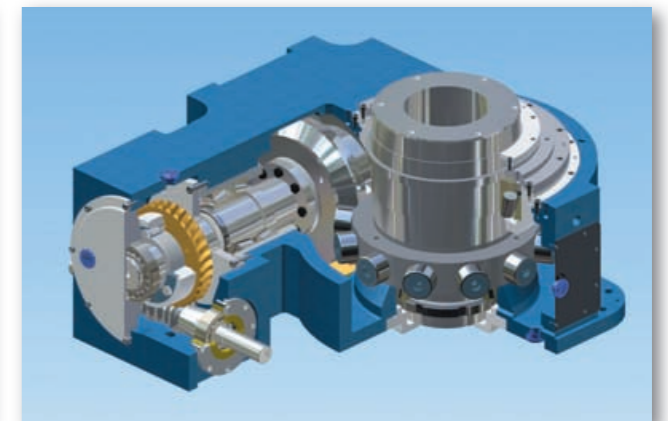

Disk Cam Gear

View of the Component Set



Disk Cam Gear, Type Y

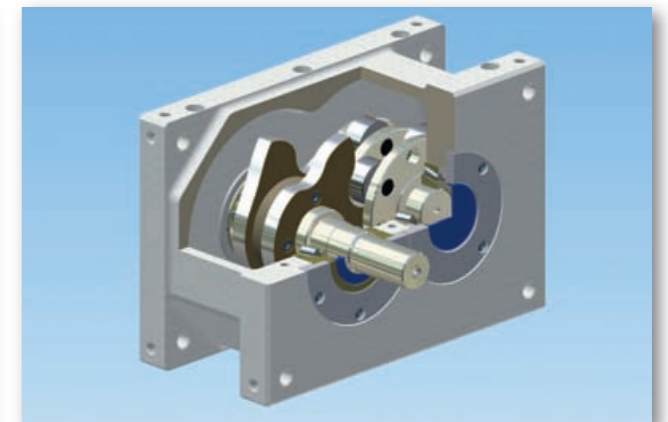

Conditions of Sale and Delivery

Our "General Conditions for the Supply of Gear Units and Drive Elements" shall apply. All dimensions and illustrations are without obligation. We reserve the right to effect changes or modifications to the construction, sizes, weights, technical specifications, etc., without prior notice. Valid 02/2007